



TORSIONALLY STIFF DISC PACK COUPLINGS 350 - 100,000 NM



GENERAL INFORMATION ABOUT R+W DISC PACK COUPLINGS:



SERVICE LIFE

R+W disc pack couplings are fatigue resistant and wear free for a virtually infinite service life, as long as the technical limits are not exceeded.

FIT CLEARANCE

Overall shaft / hub clearance of 0.01 - 0.05 mm

TEMPERATURE RANGE

-30 to +280° C

ROTATIONAL SPEED

see table





DELIVERY

pre-assembled (separate components on request)

ATEX (Optional)

Certified for use in hazardous environments on request

TORSIONALLY STIFF DISC PACK COUPLINGS 350 – 100,000 Nm

MODEL		FEATURES	
LP1 S		<p>with keyway mounting single flex design from 350 - 50,000 Nm</p> <ul style="list-style-type: none"> ▶ extremely high torsional stiffness ▶ compact and robust design ▶ compensates for axial and angular misalignment only 	Pages 70-71
LP1 D		<p>with keyway mounting dual flex design from 350 - 50,000 Nm</p> <ul style="list-style-type: none"> ▶ high torsional stiffness ▶ robust design ▶ compensates for axial, angular and lateral misalignment 	Pages 70-71
LP2		<p>with keyway mounting dual flex design with spacer from 350 - 50,000 Nm</p> <ul style="list-style-type: none"> ▶ high torsional stiffness ▶ customer specified length on request ▶ compensates for axial, angular and lateral misalignment 	Pages 72-73
LP4 S		<p>with conical clamping ring single flex design from 350 - 50,000 Nm</p> <ul style="list-style-type: none"> ▶ extremely high torsional stiffness ▶ compact design ▶ good for reversing loads ▶ zero backlash torque transmission ▶ compensates for axial and angular misalignment only 	Pages 74-75
LP4 D		<p>with conical clamping ring dual flex design from 350 - 50,000 Nm</p> <ul style="list-style-type: none"> ▶ high torsional stiffness ▶ good for reversing loads ▶ zero backlash torque transmission ▶ compensates for axial, angular and lateral misalignment 	Pages 74-75

MODEL

FEATURES

LP3



**with conical clamping ring
dual flex design
from 350 - 50,000 Nm**

Pages 76-77

- ▶ high torsional stiffness
- ▶ high clamping pressure
- ▶ good for reversing loads
- ▶ zero backlash torque transmission
- ▶ compensates for axial, angular and lateral misalignment

LP5 S



**with clamping hub
single flex design
from 350 - 50,000 Nm**

Pages 78-79

- ▶ extremely high torsional stiffness
- ▶ compact and robust design
- ▶ zero backlash torque transmission
- ▶ keyway optional
- ▶ compensates for axial and angular misalignment only

LP5 D



**with clamping hub
dual flex design
from 350 - 50,000 Nm**

Pages 78-79

- ▶ high torsional stiffness
- ▶ zero backlash torque transmission
- ▶ keyway optional
- ▶ compensates for axial, angular and lateral misalignment

LPH D



**with fully split clamping hub
dual flex design
from 350 - 50,000 Nm**

Pages 80-81

- ▶ high torsional stiffness
- ▶ facilitates lateral mounting
- ▶ zero backlash torque transmission
- ▶ keyway optional
- ▶ compensates for axial, angular and lateral misalignment

LPZ



**short intermediate spacer
for dual flex configurations
from 350 - 50,000 Nm**



Pages 82-83

- ▶ high torsional stiffness
- ▶ for combination with various hub designs
- ▶ compensates for axial, angular and lateral misalignment



TORSIONALLY STIFF DISC PACK COUPLINGS

350 – 100,000 Nm

MODEL		FEATURES	
LPA		with keyway mounting for API applications from 500 - 24,000 Nm <ul style="list-style-type: none">▶ API 610 / 671▶ drop out center section▶ safety catches in case of disc pack rupture▶ metric configuration	Pages 84-87
LPAI		with keyway mounting for API applications from 500 - 24,000 Nm <ul style="list-style-type: none">▶ API 610 / 671▶ drop out center section▶ safety catches in case of disc pack rupture▶ imperial configuration	Pages 84-87
iLP	 ARTIFICIAL INTELLIGENCE BY R+W.	intelligent coupling with integral sensor system from 350 - 50,000 Nm <ul style="list-style-type: none">▶ works with various hub designs▶ dual flex configuration▶ compensates for axial, angular and lateral misalignment▶ reports on torque, speed axial force and more	Pages 88-89
LP		options / special solutions / higher torques	Pages 90-91

DESIGN

DISC PACK COUPLINGS

Taking into account the friction drive principle of the R+W disc coupling design, torque is transferred without micro-movements or backlash.



MISALIGNMENT COMPENSATION

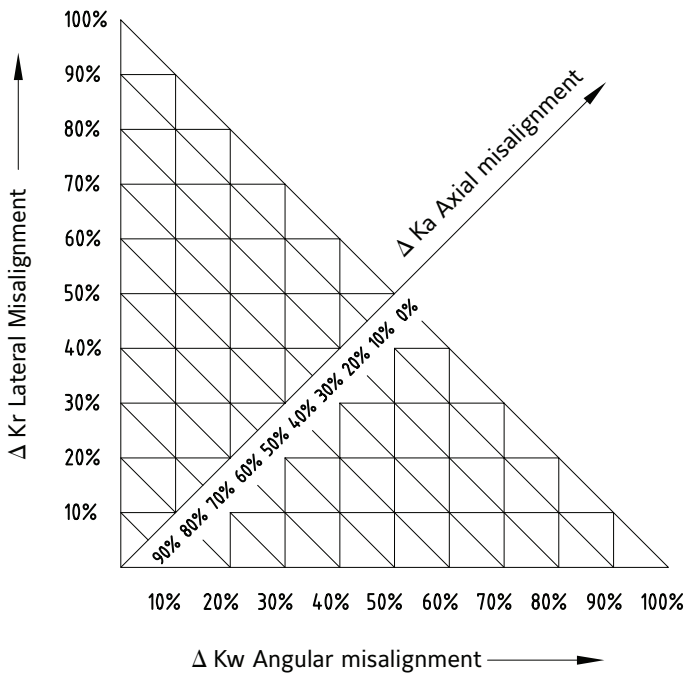

$$\Delta K_{total} = \Delta K_r + \Delta K_w + \Delta K_a \leq 100\%$$

The maximum total misalignment of the disc coupling should not exceed 100% of the combined percentages of the maximum axial, angular and lateral values as shown in the product data tables.

Example: pump skid

- axial misalignment: 20%
- lateral misalignment: 40%
- angular misalignment: 40%

$$\Delta K_{total} = 20\% + 40\% + 40\% \leq 100\%$$

➔ coupling is fatigue resistant

LP1

WITH KEYWAY MOUNTING; SINGLE OR DUAL FLEX 350 - 50,000 Nm

S = single flex design



PROPERTIES

FEATURES

- ▶ extremely high torsional stiffness
- ▶ wear and maintenance free
- ▶ compensates for axial and angular misalignment only

MATERIAL

- ▶ **disc pack:** highly elastic spring steel
- ▶ **hubs:** high strength steel

DESIGN

Two precision machined coupling hubs mounted to the disc pack by means of high strength screws and bushings for alignment and frictional clamping of the assembly. Axial retention of the hubs on the shaft with DIN 916 set screws. From series 25,000 assembly screws/superbolts must be used.

D = dual flex design



PROPERTIES

FEATURES

- ▶ high torsional stiffness
- ▶ wear and maintenance free
- ▶ compensates for axial, angular and lateral misalignment

MATERIAL

- ▶ **disc packs:** highly elastic spring steel
- ▶ **hubs and spacer:** high strength steel

DESIGN

Two precision machined coupling hubs and spacer plate mounted to the disc packs by means of high strength screws and bushings for alignment and frictional clamping of the assembly. Axial retention of the hubs on the shaft with DIN 916 set screws. From series 25,000 assembly screws/superbolts must be used.

NEW

MODEL LP1 S|D | SIZE 300 - 2600

SIZE		300		500		700		1100		1600		2600	
Type		S	D	S	D	S	D	S	D	S	D	S	D
Rated torque (Nm)	T _{KN}	350		500		700		1,100		1,600		2,600	
Maximum torque (Nm)	T _{KNmax}	700		1,000		1,400		2,200		3,200		5,200	
Overall length (mm)	A	95	123	95	123	116	154	117	158	158	204	161	208
Outside diameter (mm)	∅ AD	99		109		128		133		150		168	
Hub diameter (mm)	∅ B	63		70,5		78		84		86		102	
Hub fit length (mm)	C	45		45		55		55		75		76	
Bore diameter available from ∅ to ∅ H7 (mm)	D _{1/2}	18 - 48		23 - 50		25 - 58		25 - 60		28 - 64		31 - 75	
Bore diameter available from ∅ to ∅ H7 (XL Hub) (mm)	D _{1/2}	on request		> 50 - 60		> 58 - 65		> 60 - 70		> 64 - 80		> 75 - 90	
Assembly screw (ISO 4017) Tensioning nut (DIN 4032)	E	M8		M8		M10		M10		M12		M12	
Tightening torque (Nm)		35		40		65		95		150		165	
Distance between hubs (mm)	G	-	33	-	33	-	44	-	48	-	54	-	56
Assembly length (mm)	G ₁	60	50.3	60	50.3	75	66.4	76	66.4	98	77.5	99	77.5
Moment of inertia** (10 ⁻³ kgm ²)	J _{ges.}	2	3	3	4	5	9	7	11	12	19	22	35
Weight** (kg)		1.4	2.2	2.0	2.8	2.9	4.6	3.5	5.3	5.2	7.6	7.2	10.3
Torsional stiffness (10 ³ Nm/rad)	C _T	470	on request	500	220	1,200	on request	1,250	560	1,500	on request	1,700	800
Axial ± (mm)	max. values	0.5	1.0	0.6	1.0	0.7	1.5	0.8	1.5	1.0	2.0	1.1	2.0
Lateral ± (mm)		-	0.2	-	0.2	-	0.3	-	0.3	-	0.4	-	0.4
Angular ± (degree)		0.7	1.4	0.7	1.4	0.7	1.0	0.7	1.4	0.7	1.4	0.7	1.4
Max. speed (min ⁻¹)		5,800		5,300		4,500		4,300		3,800		3,400	
Max. speed (balanced)*** (min ⁻¹)		11,200		10,200		8,700		8,300		7,400		6,600	

** at maximum bore diameter | *** higher speeds on request

ORDERING EXAMPLE	LP1	700	D	154	25	57.15	XX
Model	●						Special designation only (e.g. special bore diameter tolerances, balancing, etc.). Contact R+W for more information
Size		●					
Type (S or D)			●				
Overall length (mm)				●			
Bore diameter ∅ D1 H7					●		
Bore diameter ∅ D2 H7						●	

For custom features place an XX at the end of the part number and describe the special requirements (e.g. LP1 / 700 / D / 154 / 25 / 57.15 / XX - balanced for 8,000 rpm)

S = single flex design

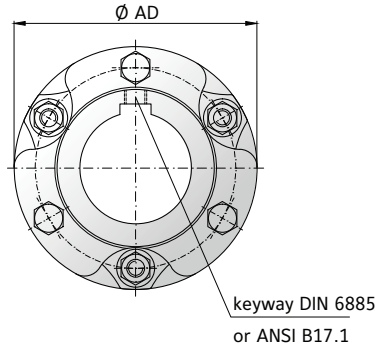
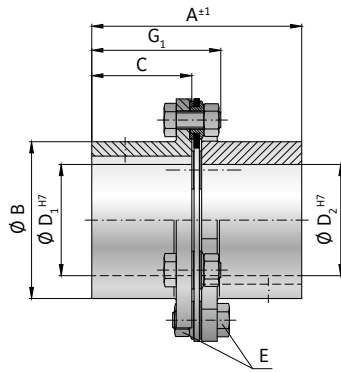

Optional XL Hub

NEW

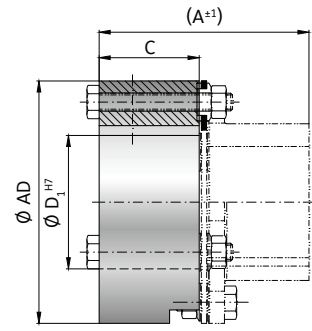

D = dual flex design

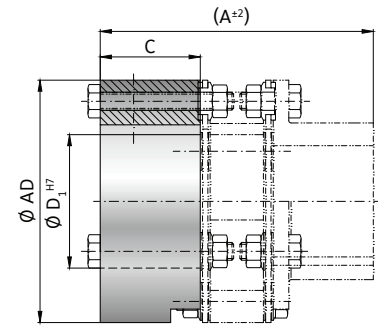
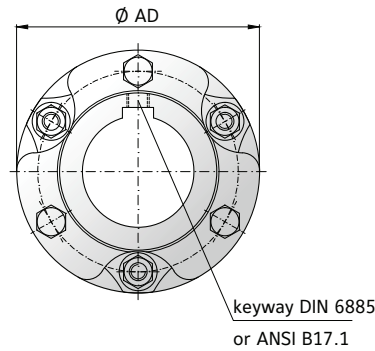
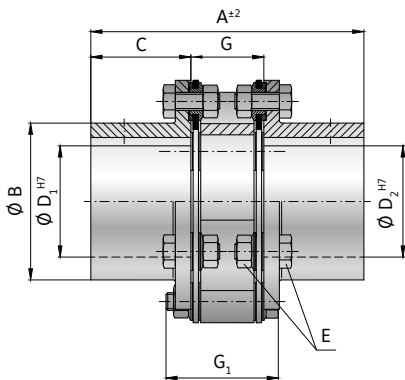

MODEL LP1 S | D | SIZE 4000 - 25000

Higher torque capacity on request

SIZE			4000		6000		8000		15000		25000	
Type			S	D	S	D	S	D	S	D	S	D
Rated torque (Nm)	T_{KH}		4,000		6,000		8,000		15,000		25,000	
Maximum torque (Nm)	T_{KNmax}		8,000		12,000		16,000		30,000		50,000	
Overall length (mm)	A		193	250	193	258	216	297	268	360	356	on request
Outside diameter (mm)	Ø AD		198		212		238		299		372	
Hub diameter (mm)	Ø B		120		130		140		192		on request	
Hub fit length (mm)	C		90		90		100		125		165	
Bore diameter available from Ø to Ø H7	$D_{1/2}$		38 - 90		39 - 95		50 - 102		70 - 150		on request	
Bore diameter available from Ø to Ø H7 (XL Hub)	$D_{1/2}$		> 90 - 100		> 95 - 115		> 102 - 125		> 150 - 170		on request	
Assembly screw (ISO 4017) Tensioning nut (DIN 4032)	E		M16		M16		M20		M24		M36	
Tightening torque (Nm)			360		400		755		1,200		72	
Distance between hubs (mm)	G		-	70	-	78	-	97	-	110	-	on request
Assembly length (mm)	G_1		120	100	120	110	140	132.5	170	155	on request	on request
Moment of inertia** (10^{-3}kgm^2)	$J_{ges.}$		51	78	66	105	113	185	426	671	718	on request
Weight** (kg)			11.7	16.9	13.6	20.1	18.8	28.4	39.0	58.1	78	on request
Torsional stiffness (10^3Nm/rad)	C_t		3,600	on request	4,000	1,700	6,000	on request	14,000	6,700	on request	
Axial ± (mm)			1.3	2.5	1.3	2.5	1.3	2.5	1.5	3.0	1.5	4.0
Lateral ± (mm)		max. values	-	0.5	-	0.5	-	0.6	-	0.7	-	0.8
Angular ± (degree)			0.7	1.4	0.7	1.4	0.7	1.4	0.7	1.4	0.7	1.4
Max. speed (min^{-1})			2,900		2,700		2,400		1,900		1,500	
Max. speed (balanced)*** (min^{-1})			5,600		5,200		4,700		3,700		3,000	

** at maximum bore diameter | *** higher speeds on request

ORDERING EXAMPLE	LP1	6000	S	193	57.15	90	XX
Model	●						
Size		●					
Type (S or D)			●				
Overall length (mm)				●			
Bore diameter Ø D1 H7					●		
Bore diameter Ø D2 H7						●	
Special designation only (e.g. special bore diameter tolerances, balancing, etc.). Contact R+W for more information.							

For custom features place an XX at the end of the part number and describe the special requirements (e.g. LP1 / 6000 / S / 193 / 57.15 / 90 / XX - F7 tolerance on D2)

LP2

WITH KEYWAY MOUNTING

350 - 5,200 Nm



PROPERTIES



FEATURES

- ▶ high torsional stiffness
- ▶ dual flex design
- ▶ customer specified length on request

MATERIAL

- ▶ **disc packs:** highly elastic spring steel
- ▶ **hubs and spacer:** high strength steel

DESIGN

Two precision machined coupling hubs and spacer mounted to the disc packs by means of high strength screws and bushings for alignment and frictional clamping of the assembly. Axial retention of the hubs on the shaft with DIN 916 set screws. From series 25,000 assembly screws/superbolts must be used.

Optional XL Hub

NEW

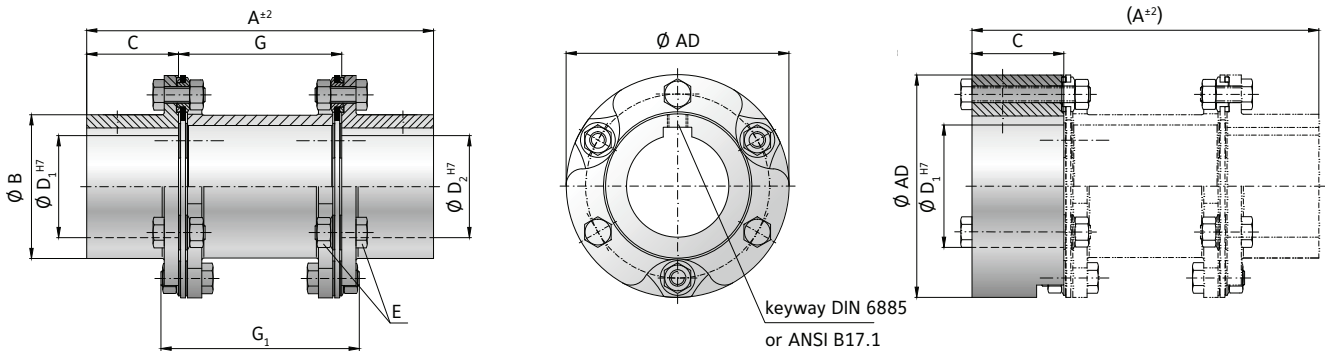

MODEL LP2 | SIZE 300 - 2600

SIZE			300	500	700	1100	1600	2600
Rated torque	(Nm)	T_{KN}	350	500	700	1,100	1,600	2,600
Maximum torque	(Nm)	T_{KNmax}	700	1,000	1,400	2,200	3,200	5,200
Overall length	(mm)	A	170	170	205	206	286	286
Outside diameter	(mm)	$\varnothing AD$	99	109	128	133	150	168
Hub diameter	(mm)	$\varnothing B$	63	70.5	78	84	86	102
Hub fit length	(mm)	C	45	45	55	55	75	76
Bore diameter available from \varnothing to $\varnothing H7$	(mm)	$D_{3/2}$	18 - 48	23 - 50	25 - 58	25 - 60	28 - 64	31 - 75
Bore diameter available from \varnothing to $\varnothing H7$ (XL Hub)	(mm)	$D_{3/2}$	on request	> 50 - 60	> 58 - 65	> 60 - 70	> 64 - 80	> 75 - 90
Assembly screw	(ISO 4017)	E	M8	M8	M10	M10	M12	M12
Tensioning nut	(DIN 4032)							
Tightening torque	(Nm)		35	40	65	95	150	165
Distance between hubs	(mm)	G	80	80	95	96	136	134
Assembly length	(mm)	G_1	100	100	121	118	171	166
Moment of inertia**	($10^{-3}kgm^2$)	J_{ges}	4	6	12	16	29	51
Weight**	(kg)		3.1	4.4	6.1	7.6	11.5	15.0
Torsional stiffness	($10^3Nm/rad$)	C_T	220	230	550	570	700	900
Axial \pm	(mm)	max. values	1	1	1.5	1.5	2	2
Lateral \pm	(mm)		0.8	0.8	1	1	1.4	1.4
Angular \pm	(degree)		1.4	1.4	1.4	1.4	1.4	1.4
Max. speed	(min^{-1})		5,800	5,300	4,500	4,300	3,800	3,400
Max. speed (balanced)***	(min^{-1})		11,200	10,200	8,700	8,300	7,400	6,600

** at maximum bore diameter | *** higher speeds on request

ORDERING EXAMPLE	LP2	500	170	25.4	48	XX
Model	●					Special designation only (e.g. special bore diameter tolerances, balancing, etc.). Contact R+W for more information.
Size		●				
Overall length (mm)			●			
Bore diameter $\varnothing D1 H7$				●		
Bore diameter $\varnothing D2 H7$					●	
For custom features place an XX at the end of the part number and describe the special requirements (e.g. LP2 / 500 / 170 / 25.4 / 48 / XX - balanced for 10,000 rpm)						

LP2

WITH KEYWAY MOUNTING

4,000 – 50,000 Nm



PROPERTIES

FEATURES

- ▶ high torsional stiffness
- ▶ dual flex design
- ▶ customer specified length on request

MATERIAL

- ▶ **disc packs:** highly elastic spring steel
- ▶ **hubs and spacer:** high strength steel

DESIGN

Two precision machined coupling hubs and spacer mounted to the disc packs by means of high strength screws and bushings for alignment and frictional clamping of the assembly. Axial retention of the hubs on the shaft with DIN 916 set screws. From series 25,000 assembly screws/superbolts must be used.

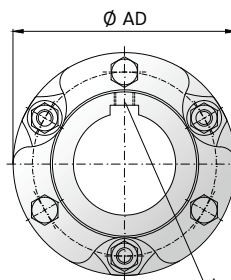
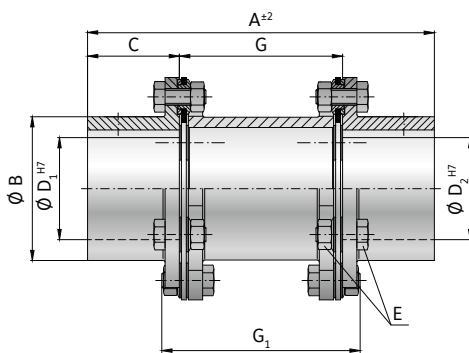

Optional XL Hub

NEW

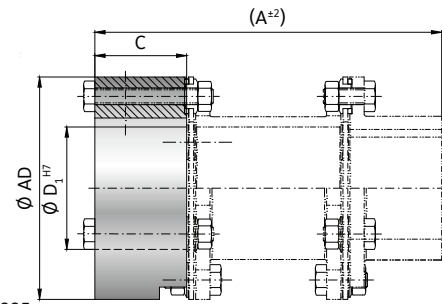

MODEL LP2 | SIZE 4000 - 25000

Higher torque capacity on request

SIZE			4000	6000	8000	15000	25000
Rated torque	(Nm)	T_{KN}	4,000	6,000	8,000	15,000	25,000
Maximum torque	(Nm)	T_{KNmax}	8,000	12,000	16,000	30,000	50,000
Overall length	(mm)	A	320	340	372	480	on request
Outside diameter	(mm)	$\varnothing AD$	198	212	238	299	372
Hub diameter	(mm)	$\varnothing B$	120	130	140	192	on request
Hub fit length	(mm)	C	90	90	100	125	165
Bore diameter available from \varnothing to $\varnothing H7$	(mm)	$D_{1/2}$	38 - 90	39 - 95	50 - 102	70 - 150	on request
Bore diameter available from \varnothing to $\varnothing H7$ (XL Hub)	(mm)	$D_{1/2}$	> 90 - 100	> 95 - 115	> 102 - 125	> 150 - 170	on request
Assembly screw	(ISO 4017)	E	M16	M16	M20	M24	M36
Tensioning nut	(DIN 4032)						
Tightening torque	(Nm)		360	400	755	1,200	72
Distance between hubs	(mm)	G	140	160	172	230	on request
Assembly length	(mm)	G_1	178	198	216	294.2	on request
Moment of inertia**	($10^{-3}kgm^2$)	$J_{ges.}$	119	151	267	790	on request
Weight**	(kg)		28.4	28.4	41.2	70.1	on request
Torsional stiffness	($10^3Nm/rad$)	C_1	1,700	1,900	2,800	7,000	on request
Axial \pm	(mm)	max. values	2.5	2.5	2.5	3	4
Lateral \pm	(mm)		1.4	1.5	1.6	2.2	2.6
Angular \pm	(Grad)		1.4	1.4	1.4	1.4	1.4
Max. speed	(min^{-1})		2,900	2,700	2,400	1,900	1,500
Max. speed (balanced)***	(min^{-1})		5,600	5,200	4,700	3,700	3,000

** at maximum bore diameter | *** higher speeds on request

ORDERING EXAMPLE	LP2	6000	340	50.8	90	XX
Model	●					Special designation only (e.g. special bore diameter tolerances, balancing, etc.). Contact R+W for more information.
Size		●				
Overall length (mm)			●			
Bore diameter $\varnothing D1 H7$				●		
Bore diameter $\varnothing D2 H7$					●	

For custom features place an XX at the end of the part number and describe the special requirements (e.g. LP2 / 6000 / 340 / 50.8 / 90 / XX - F7 bore tolerance on D2)

DISC PACK COUPLINGS LP

LP4

WITH CONICAL CLAMPING RING; SINGLE OR DUAL FLEX 350 - 50,000 Nm

S = single flex design



PROPERTIES

FEATURES

- ▶ extremely high torsional stiffness
- ▶ good for reversing loads
- ▶ compensates for axial and angular misalignment only

MATERIAL

- ▶ **disc pack:** highly elastic spring steel
- ▶ **hubs:** high strength steel

DESIGN

Two precision machined coupling hubs with conical clamping ring mounted to the disc pack by means of high strength screws and bushings for alignment and frictional clamping of the assembly.

From series 25,000 assembly screws/superbolts must be used.

D = dual flex design



PROPERTIES

FEATURES

- ▶ high torsional stiffness
- ▶ good for reversing loads
- ▶ compensates for axial, angular and lateral misalignment

MATERIAL

- ▶ **disc packs:** highly elastic spring steel
- ▶ **hubs and spacer:** high strength steel

DESIGN

Two precision machined coupling hubs with conical clamping ring and spacer plate mounted to the disc packs by means of high strength screws and bushings for alignment and frictional clamping of the assembly.

NEW

MODEL LP4 S|D | SIZE 300 - 2600

SIZE		300		500		700		1100		1600		2600	
Type		S	D	S	D	S	D	S	D	S	D	S	D
Rated torque* (Nm)	T_{KN}	350		500		700		1,100		1,600		2,600	
Maximum torque* (Nm)	T_{KNmax}	700		1,000		1,400		2,200		3,200		5,200	
Overall length (mm)	A	76	104	76	104	93	131	99	140	120	166	136	183
Outside diameter (mm)	$\varnothing AD$	99		109		128		133		150		168	
Hub diameter (mm)	$\varnothing B$	95		105		122		130		146		165	
Hub fit length (mm)	C	35.5		35.5		43.5		46		56		63.5	
Bore diameter available from \varnothing to $\varnothing H7$ (mm)	$D_{1/2}$	24 - 50		24 - 55		30 - 65		30 - 65		35 - 70		35 - 85	
Assembly screw (ISO 4017) Tensioning nut (DIN 4032)	E	M8		M8		M10		M10		M12		M12	
Tightening torque (Nm)		35		40		65		95		150		165	
Distance between hubs (mm)	G	-	33	-	33	-	44	-	48	-	54	-	56
Assembly length (mm)	G_1	50.5	50.3	50.5	50.3	62.5	66.4	64	66.4	81	77.5	88.5	77.5
Clamping screw (ISO 4017)	H	6 x M8		6 x M8		6 x M10		6x M10		6 x M12		6 x M12	
Tightening torque (Nm)		20		26		39		61		98		140	
Moment of inertia** ($10^{-3}kgm^2$)	$J_{ges.}$	3	4	5	7	12	15	16	20	31	38	89	71
Weight** (kg)		2.4	3.1	3.0	3.9	5.1	6.6	6.1	7.9	9.7	12.1	14.4	17.5
Torsional stiffness ($10^3Nm/rad$)	C_T	on request		500	220	on request		1,250	560	on request		1,700	800
Axial \pm (mm)	max. values	0.5	1.0	0.6	1.0	0.7	1.5	0.8	1.5	1.0	2.0	1.1	2.0
Lateral \pm (mm)		-	0.2	-	0.2	-	0.3	-	0.3	-	0.4	-	0.4
Angular \pm (degree)		0.7	1.4	0.7	1.4	0.7	1.4	0.7	1.4	0.7	1.4	0.7	1.4
Max. speed (min ⁻¹)		5,800		5,300		4,500		4,300		3,800		3,400	
Max. speed (balanced)*** (min ⁻¹)		11,200		10,200		8,700		8,300		7,400		6,600	

* maximum transmittable torque depends on the bore diameter | ** at maximum bore diameter | *** higher speeds on request

SIZE	$\varnothing 24$	$\varnothing 26$	$\varnothing 30$	$\varnothing 35$	$\varnothing 40$	$\varnothing 45$	$\varnothing 50$	$\varnothing 55$	$\varnothing 60$	$\varnothing 70$	$\varnothing 80$	$\varnothing 90$	$\varnothing 100$	$\varnothing 110$	$\varnothing 120$	$\varnothing 130$	$\varnothing 140$	$\varnothing 160$	$\varnothing 180$
300	330	360	420	490	560	630	700												
500	430	470	540	640	730	820	910	1000											
700			650	760	870	980	1090	1200	1310										
1100			1020	1190	1370	1540	1710	1880	2050										
1600				1610	1840	2070	2300	2530	2760	3200									
2600				2300	2620	2950	3280	3610	3940	4600	5200								
4000							4000	4400	4800	5600	6400	7200	8000						
6000							5400	6000	6500	7600	8700	9800	10900	12000					
8000									8300	9700	11100	12500	13900	15300					
15000										12000	14000	15500	17500	19000	21000	22500	24500	28000	
25000													28000	30500	33500	36000	39000	44500	50000

Higher torque capacity possible with keyway or spline on request.

S = single flex design

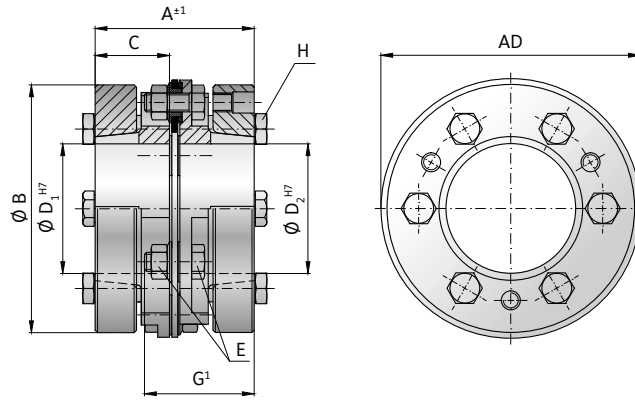

D = dual flex design

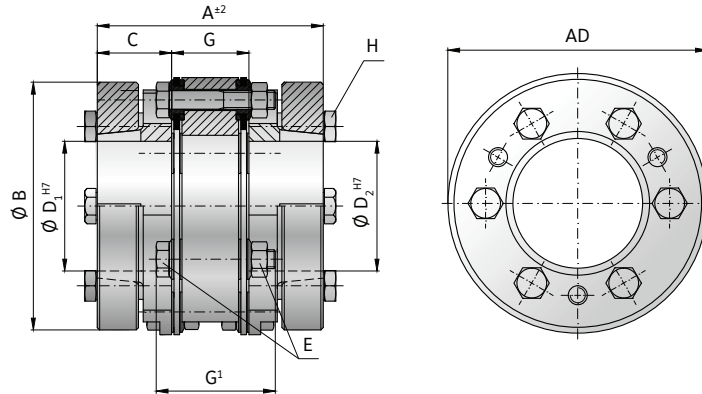

MODEL LP4 S | D | SIZE 4000 - 25000

SIZE			4000		6000		8000		15000		25000	
Type			S	D	S	D	S	D	S	D	S	D
Rated torque*	(Nm)	T_{KN}	4,000		6,000		8,000		15,000		25,000	
Maximum torque*	(Nm)	T_{KNmax}	8,000		12,000		16,000		30,000		50,000	
Overall length	(mm)	A	161	218	174	239	226	307	264	356	274	on request
Outside diameter	(mm)	Ø AD	198		212		238		299		372	
Hub diameter	(mm)	Ø B	184		205		230		285		on request	
Hub fit length	(mm)	C	74		80.5		105		123		124	
Bore diameter available from Ø to Ø H7	(mm)	$D_{1/2}$	50 - 100		50 - 110		60 - 115		70 - 170		on request	
Assembly screw (ISO 4017) Tensioning nut (DIN 4032)		E	M16		M16		M20		M24		M36	
Tightening torque	(Nm)		360		400		755		1,200		72	
Distance between hubs	(mm)	G	-	70	-	78	-	97	-	110	-	on request
Assembly length	(mm)	G_1	106	100	112.5	110	148	142.5	173	155	on request	on request
Clamping screw (ISO 4017)		H	6 x M16		6 x M16		6 x M20		6 x M20		6 x M24	
Tightening torque	(Nm)		225		400		490		620		1.180	
Moment of inertia**	(10^{-3}kgm^2)	$J_{ges.}$	110	137	172	211	368	440	1,003	1,248	1,469	on request
Weight**	(kg)		19.9	25.1	25.9	32.4	45.4	54.9	73.3	92.3	116	on request
Torsional stiffness	(10^3Nm/rad)	C_T	on request		3,800	1,700	on request		13,800	6,600	on request	
Axial ±	(mm)	max. values	1.3	2.5	1.3	2.5	1.3	2.5	1.5	3.0	1.5	4.0
Lateral ±	(mm)		-	0.5	-	0.5	-	0.6	-	0.7	-	0.8
Angular ±	(degree)		0.7	1.4	0.7	1.4	0.7	1.4	0.7	1.4	0.7	1.4
Max. speed	(min^{-1})		2,900		2,700		2,400		1,900		1,500	
Max. speed (balanced)***	(min^{-1})		5,600		5,200		4,700		3,700		3,000	

* maximum transmittable torque depends on the bore diameter | ** at maximum bore diameter | *** higher speeds on request

ORDERING EXAMPLE	LP4	6000	D	239	55	80	XX
Model	●						Special designation only (e.g. special bore diameter tolerances, balancing, etc.). Contact R+W for more information.
Size		●					
Type (S or D)			●				
Overall length (mm)				●			
Bore diameter Ø D1 H7					●		
Bore diameter Ø D2 H7						●	
For custom features place an XX at the end of the part number and describe the special requirements (e.g. LP4 / 6000 / D / 239 / 55 / 80 / XX - F7 bore tolerance on D2)							



WITH CONICAL CLAMPING RING

350 - 5,200 Nm



PROPERTIES



FEATURES

- ▶ high torsional stiffness
- ▶ customer specified length on request
- ▶ good for reversing loads

MATERIAL

- ▶ **disc packs:** highly elastic spring steel
- ▶ **hubs and spacer:** high strength steel

DESIGN

Two precision machined coupling hubs with conical clamping ring and spacer mounted to the disc packs by means of high strength screws and bushings for alignment and frictional clamping of the assembly.
From series 25,000 assembly screws/superbolts must be used.

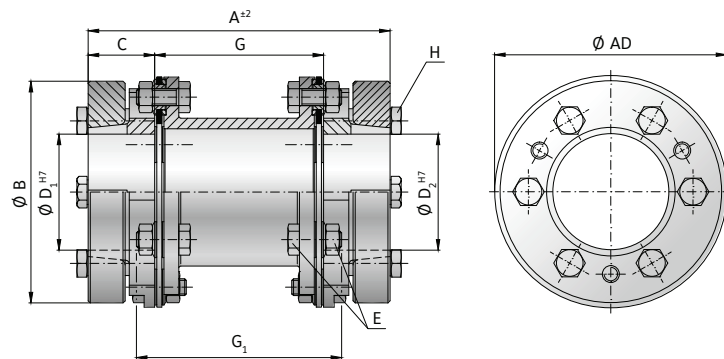

MODEL LP3 | SIZE 300 - 2600

SIZE			300	500	700	1100	1600	2600
Rated torque*	(Nm)	T_{KN}	350	500	700	1,100	1,600	2,600
Maximum torque*	(Nm)	T_{KNmax}	700	1,000	1,400	2,200	3,200	5,200
Overall length	(mm)	A	151	151	182	188	248	261
Outside diameter	(mm)	$\varnothing AD$	99	109	128	133	150	168
Hub diameter	(mm)	$\varnothing B$	95	105	122	130	146	165
Hub fit length	(mm)	C	35.5	35.5	43.5	46	56	63.5
Bore diameter available from \varnothing to $\varnothing H7$	(mm)	$D_{1/2}$	24 - 50	24 - 55	30 - 65	30 - 65	35 - 70	35 - 85
Assembly screw (ISO 4017) Tensioning nut (DIN 4032)		E	M8	M8	M10	M10	M12	M12
Tightening torque	(Nm)		35	40	65	95	150	165
Distance between hubs	(mm)	G	80	80	95	96	136	134
Assembly length	(mm)	G_1	100	100	121	118	170	166
Clamping screw (ISO 4017)		H	6 x M8	6 x M8	6 x M10	6 x M10	6 x M12	6 x M12
Tightening torque	(Nm)		20	26	39	61	98	140
Moment of inertia**	(10^{-3}kgm^2)	$J_{ges.}$	5	7	16	21	41	76
Weight**	(kg)		3.5	4.5	7.0	8.4	13.5	19.1
Torsional stiffness	(10^3Nm/rad)	C_T	220	230	550	570	700	900
Axial \pm	(mm)		1	1	1.5	1.5	2	2
Lateral \pm	(mm)	max. values	0.8	0.8	1	1	1.4	1.4
Angular \pm	(degree)		1.4	1.4	1.4	1.4	1.4	1.4
Max. speed	(min^{-1})		5,800	5,300	4,500	4,300	3,800	
Max. speed (balanced)***	(min^{-1})		11,200	10,200	8,700	8,300	7,400	6,600

* maximum transmittable torque depends on the bore diameter | ** at maximum bore diameter | *** higher speeds on request

SIZE	$\varnothing 24$	$\varnothing 26$	$\varnothing 30$	$\varnothing 35$	$\varnothing 40$	$\varnothing 45$	$\varnothing 50$	$\varnothing 55$	$\varnothing 60$	$\varnothing 70$	$\varnothing 80$	$\varnothing 90$	$\varnothing 100$	$\varnothing 110$	$\varnothing 120$	$\varnothing 130$	$\varnothing 140$	$\varnothing 160$	$\varnothing 180$
300	330	360	420	490	560	630	700												
500	430	470	540	640	730	820	910	1000											
700			650	760	870	980	1090	1200	1310										
1100			1020	1190	1370	1540	1710	1880	2050										
1600				1610	1840	2070	2300	2530	2760	3200									
2600				2300	2620	2950	3280	3610	3940	4600	5200								
4000							4000	4400	4800	5600	6400	7200	8000						
6000							5400	6000	6500	7600	8700	9800	10900	12000					
8000								8300	9700	11100	12500	13900	15300						
15000										12000	14000	15500	17500	19000	21000	22500	24500	28000	
25000													28000	30500	33500	36000	39000	44500	50000

Higher torque capacity possible with keyway or spline on request.

LP3

WITH CONICAL CLAMPING RING

4,000 – 50,000 Nm



PROPERTIES



FEATURES

- ▶ high torsional stiffness
- ▶ customer specified length on request
- ▶ good for reversing loads

MATERIAL

- ▶ **disc packs:** highly elastic spring steel
- ▶ **hubs and spacer:** high strength steel

DESIGN

Two precision machined coupling hubs with conical clamping ring and spacer mounted to the disc packs by means of high strength screws and bushings for alignment and frictional clamping of the assembly. From series 25,000 assembly screws/superbolts must be used.

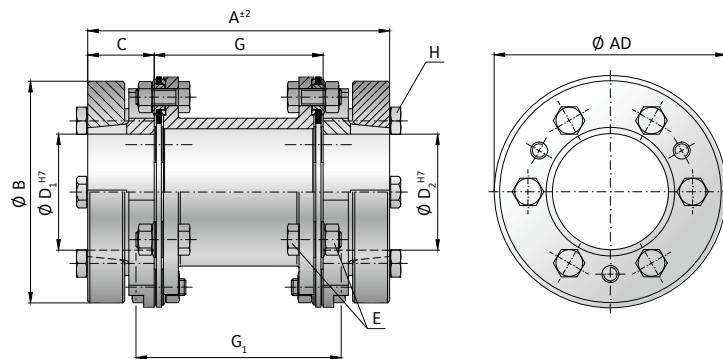

MODEL LP3 | SIZE 4000 - 25000

SIZE			4000	6000	8000	15000	25000
Rated torque*	(Nm)	T_{KN}	4,000	6,000	8,000	15,000	25,000
Maximum torque*	(Nm)	T_{KNmax}	8,000	12,000	16,000	30,000	50,000
Overall length	(mm)	A	288	321	382	476	on request
Outside diameter	(mm)	$\varnothing AD$	198	212	238	299	372
Hub diameter	(mm)	$\varnothing B$	184	205	230	285	on request
Hub fit length	(mm)	C	74	80.5	105	123	124
Bore diameter available from \varnothing to $\varnothing H7$	(mm)	$D_{1/2}$	50 - 100	50 - 110	60 - 115	70 - 170	on request
Assembly screw (ISO 4017) Tensioning nut (DIN 4032)		E	M16	M16	M20	M24	M36
Tightening torque	(Nm)		360	400	755	1,200	72
Distance between hubs	(mm)	G	140	160	172	230	on request
Assembly length	(mm)	G_1	178	198	226	295	on request
Clamping screw (ISO 4017)		H	6 x M16	6 x M16	6 x M20	6 x M20	6 x M24
Tightening torque	(Nm)		225	308	490	620	,180
Moment of inertia**	($10^{-3}kgm^2$)	$J_{ges.}$	149	225	456	1,344	on request
Weight**	(kg)		27.9	34.9	57.7	99.9	on request
Torsional stiffness	($10^3Nm/rad$)	C_T	1,700	1,900	2,800	7,000	on request
Axial \pm	(mm)		2.5	2.5	2.5	3	4
Lateral \pm	(mm)	max. values	1.4	1.5	1.6	2.2	2.6
Angular \pm	(degree)		1.4	1.4	1.4	1.4	1.4
Max. speed	(min^{-1})		2,900	2,700	2,400	1,900	1,500
Max. speed (balanced)***	(min^{-1})		5,600	5,200	4,700	3,700	3,000

* maximum transmittable torque depends on the bore diameter | ** at maximum bore diameter | *** higher speeds on request

ORDERING EXAMPLE	LP3	6000	321	50.8	75	XX
Model	●					Sonderanfertigungen (z.B. andere Gesamtlänge) on request möglich.
Size		●				
Overall length (mm)			●			
Bore diameter $\varnothing D1 H7$				●		
Bore diameter $\varnothing D2 H7$					●	

For custom features place an XX at the end of the part number and describe the special requirements (e.g. LP3 / 6000 / 321 / 50.8 / 75 / XX - F7 bore tolerance on D2)

DISC PACK COUPLINGS
LP

LP5

WITH CLAMPING HUB; SINGLE OR DUAL FLEX 350 - 50,000 Nm

S = single flex design



NEW

D = dual flex design



NEW

PROPERTIES

FEATURES

- ▶ easy installation
- ▶ keyway optional
- ▶ compensates for axial and angular misalignment only

MATERIAL

- ▶ **disc pack:** highly elastic spring steel
- ▶ **hubs:** high strength steel

DESIGN

Two precision machined split clamping hubs mounted to the disc pack by means of high strength screws and bushings for alignment and frictional clamping of the assembly.

From series 25,000 assembly screws/superbolts must be used.

PROPERTIES

FEATURES

- ▶ easy installation
- ▶ keyway optional
- ▶ compensates for axial, angular and lateral misalignment

MATERIAL

- ▶ **disc packs:** highly elastic spring steel
- ▶ **hubs and spacer:** high strength steel

DESIGN

Two precision machined split clamping hubs and spacer plate mounted to the disc packs by means of high strength screws and bushings for alignment and frictional clamping of the assembly.

MODEL LP5 S|D | SIZE 300 - 2600

SIZE		300		500		700		1100		1600		2600	
Type		S	D	S	D	S	D	S	D	S	D	S	D
Rated torque* (Nm)	T_{KN}	350		500		700		1,100		1,600		2,600	
Maximum torque* (Nm)	T_{KNmax}	700		1,000		1,400		2,200		3,200		5,200	
Overall length (mm)	A	on request		108	137	on request		on request		178	224	189	236
Outside diameter (mm)	$\varnothing AD$	99		109		128		133		150		168	
Hub diameter (mm)	$\varnothing B$	72		80		89		95		103		122	
Hub fit length (mm)	C	43		52		on request		on request		85		90	
Bore diameter available from \varnothing to $\varnothing H7$ (mm)	$D_{1/2}$	18 - 48		23 - 50		25 - 58		25 - 60		28 - 64		31 - 75	
Assembly screw (ISO 4017) Tensioning nut (DIN 4032)	E	M8		M8		M10		M10		M12		M12	
Tightening torque (Nm)		35		40		65		95		150		165	
Distance between hubs (mm)	G	-	33	-	33	-	44	-	48	-	54	-	56
Assembly length (mm)	G_1	59	50.3	68	50.3	84	66.4	94	66.4	113	77.5	119	77.5
Clamping screw (ISO 4762)	H	4 x M6		4 x M8		4 x M8		4 x M10		4 x M12		4 x M14	
Tightening torque (Nm)		18		34		39		73		120		192	
Moment of inertia** (10^{-3}kgm^2)	$J_{ges.}$	2	3	4	5	8	11	11	15	20	27	38	50
Weight** (kg)		1.8	2.5	2.8	3.7	4.3	6.0	5.5	7.4	8.4	10.6	12.0	15.1
Torsional stiffness (10^3Nm/rad)	C_T	on request											
Axial \pm (mm)	max. values	0.5	1.0	0.6	1.0	0.7	1.5	0.8	1.5	1.0	2.0	1.1	2.0
Lateral \pm (mm)		-	0.2	-	0.2	-	0.3	-	0.3	-	0.4	-	0.4
Angular \pm (degree)		0.7	1.4	0.7	1.4	0.7	1.4	0.7	1.4	0.7	1.4	0.7	1.4
Max. speed (min^{-1})		5,800		5,300		4,500		4,300		3,800		3,400	
Max. speed (balanced)*** (min^{-1})		11,200		10,200		8,700		8,300		7,400		6,600	

* maximum transmittable torque depends on the bore diameter | ** at maximum bore diameter | *** higher speeds on request

SIZE	$\varnothing 18$	$\varnothing 20$	$\varnothing 23$	$\varnothing 25$	$\varnothing 30$	$\varnothing 35$	$\varnothing 40$	$\varnothing 45$	$\varnothing 50$	$\varnothing 55$	$\varnothing 60$	$\varnothing 70$	$\varnothing 80$	$\varnothing 90$	$\varnothing 100$	$\varnothing 120$	$\varnothing 140$	$\varnothing 150$	$\varnothing 160$	
300	170	190	220	240	290	340	390	430												
500			310	330	400	470	530	600	650											
700				390	470	550	630	710	790	870										
1100				590	710	830	950	1070	1190	1300	1430									
1600					980	1150	1310	1470	1640	1800	1970									
2600						1580	1800	2030	2250	2480	2700	3160								
4000							2300	2600	2800	3100	3400	4000	4600	5200						
6000							3200	3600	4100	4500	4900	5700	6500	7300						
8000									5100	8600	6100	7100	8100	9200	10200					
15000												9000	10000	11500	13000	15500	18000	19500		
25000															19000	23000	26500	28500	30500	

Higher torque capacity possible with keyway or spline on request.

S = single flex design

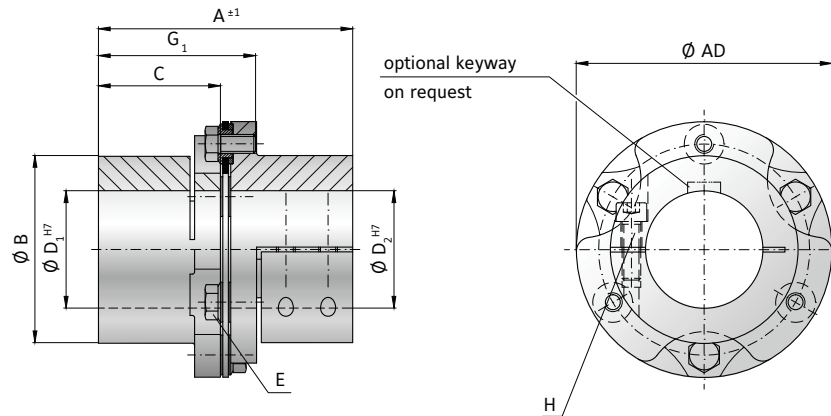

D = dual flex design

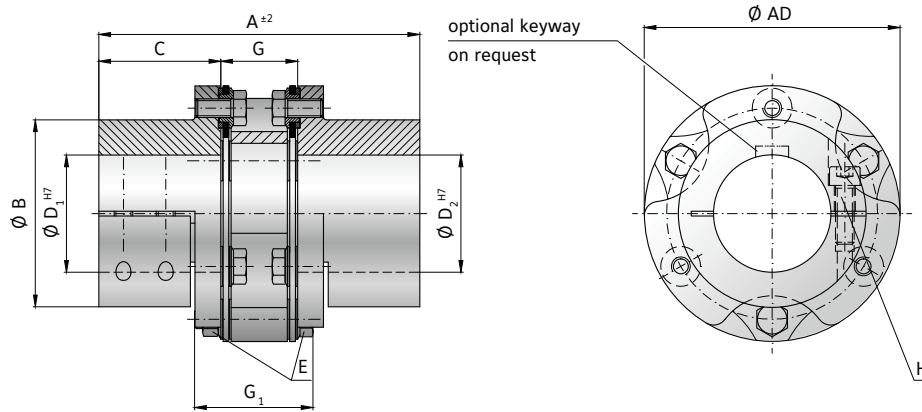

MODEL LP5 S | D | SIZE 4000 - 25000

SIZE			4000		6000		8000		15000		25000	
Type			S	D	S	D	S	D	S	D	S	D
Rated torque*	(Nm)	T_{KN}	4,000		6,000		8,000		15,000		25,000	
Maximum torque*	(Nm)	T_{KNmax}	8,000		12,000		16,000		30,000		50,000	
Overall length	(mm)	A	217	274	on request		on request		328	420	392	on request
Outside diameter	(mm)	Ø AD	198		212		238		299		372	
Hub diameter	(mm)	Ø B	137		151		168		220		on request	
Hub fit length	(mm)	C	102		on request		on request		155		183	
Bore diameter available from Ø to Ø H7	(mm)	$D_{1/2}$	38 - 90		39 - 95		50 - 102		70 - 150		on request	
Assembly screw (ISO 4017)		E	M16		M16		M20		M24		M36	
Tensioning nut (DIN 4032)			360		400		755		1,200		72	
Tightening torque	(Nm)		360		400		755		1,200		72	
Distance between hubs	(mm)	G	-	70	-	78	-	97	-	110	-	on request
Assembly length	(mm)	G_1	140.8	100	151	110	174	132.5	212	155	on request	on request
Clamping screw (ISO 4762)		H	4 x M14		4 x M16		4 x M20		8 x M20		8 x M24	
Tightening torque	(Nm)			246		395		615		680		1,200
Moment of inertia**	(10^{-3}kgm^2)	$J_{ges.}$	75	103	106	145	207	279	658	904	1.147	on request
Weight**	(kg)		17.3	22.5	21.9	28.4	33.8	43.4	61.2	80.3	on request	on request
Torsional stiffness	(10^3Nm/rad)	C_T	on request									
Axial ±	(mm)	max, values	1.3	2.5	1.3	2.5	1.3	2.5	1.5	3.0	1.5	4.0
Lateral ±	(mm)		-	0.5	-	0.5	-	0.6	-	0.7	-	0.8
Angular ±	(degree)		0.7	1.4	0.7	1.4	0.7	1.4	0.7	1.4	0.7	1.4
Max, speed	(min^{-1})		2,900		2,700		2,400		1,900		1,500	
Max, speed (balanced)***	(min^{-1})		5,600		5,200		4,700		3,700		3,000	

* maximum transmittable torque depends on the bore diameter | ** at maximum bore diameter | *** higher speeds on request

ORDERING EXAMPLE	LP5	700	S	133	25.4	40	XX
Model	●						Special designation only (e.g. special bore diameter tolerances, balancing, etc.). Contact R+W for more information.
Size		●					
Type (S or D)			●				
Overall length (mm)				●			
Bore diameter Ø D1 H7					●		
Bore diameter Ø D2 H7						●	
For custom features place an XX at the end of the part number and describe the special requirements (e.g. LP5 / 700 / S / 133 / 25.4 / 40 / XX - balanced to 10,000 rpm)							

LPH

WITH FULLY SPLIT CLAMPING HUB

350 - 5,200 Nm



NEW

PROPERTIES

FEATURES

- ▶ lateral mounting between shafts
- ▶ easy installation and removal
- ▶ dual flex design

MATERIAL

- ▶ **disc packs:** highly elastic spring steel
- ▶ **hubs and spacer:** high strength steel

DESIGN

Two precision machined fully split clamping hubs and spacer plate mounted to the disc pack by means of high strength screws and bushings for alignment and frictional clamping of the assembly. From series 25,000 assembly screws/superbolts must be used.

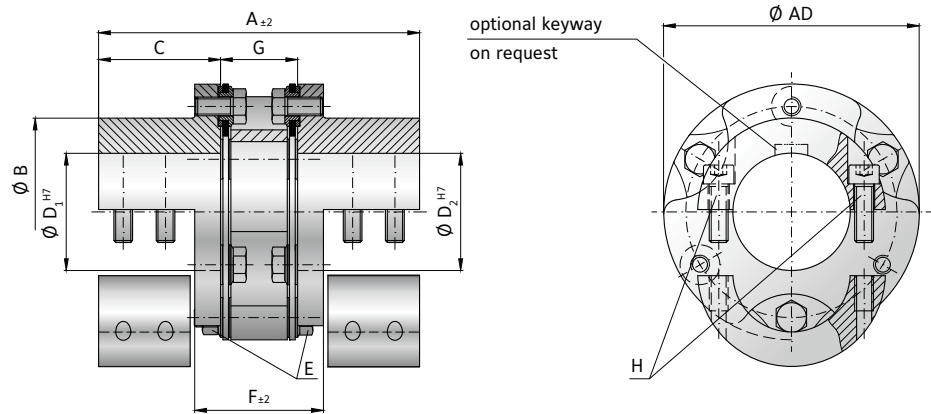

MODEL LPH D | SIZE 300 - 2600

SIZE			300	500	700	1100	1600	2600
Rated torque*	(Nm)	T_{KN}	350	500	700	1,100	1,600	2,600
Maximum torque*	(Nm)	T_{KNmax}	700	1,000	1,400	2,200	3,200	5,200
Overall length	(mm)	A	119	137	172	192	224	236
Outside diameter	(mm)	ϕAD	99	109	128	133	150	168
Hub diameter	(mm)	ϕB	72	80	89	95	100	116.5
Hub fit length	(mm)	C	43	52	64	72	85	90
Bore diameter available from ϕ to $\phi H7$	(mm)	$D_{1/2}$	18 - 48	23 - 50	25 - 58	25 - 60	28 - 64	31 - 75
Assembly screw (ISO 4017) Tensioning nut (DIN 4032)		E	M8	M8	M10	M10	M12	M12
Tightening torque	(Nm)		35	40	65	95	150	165
Length of center section	(mm)	F	58	58	74	80	96	98
Distance between hubs	(mm)	G	33	33	44	48	54	56
Clamping screw (ISO 4762)		H	8 x M6	8 x M8	8 x M8	8 x M10	8 x M10	8 x M12
Tightening torque	(Nm)		16	28	34	63	86	143
Moment of inertia**	($10^{-3}kgm^2$)	$J_{ges.}$	3	5	11	15	26	48
Weight**	(kg)		2.5	3.7	6.0	7.4	10.3	14.6
Torsional stiffness	($10^3Nm/rad$)	C_T	on request					
Axial \pm	(mm)	max. values	1.0	1.0	1.5	1.5	2.0	2.0
Lateral \pm	(mm)		0.2	0.2	0.3	0.3	0.4	0.4
Angular \pm	(degree)		1.4	1.4	1.4	1.4	1.4	1.4
Max. speed	(min^{-1})		5,800	5,300	4,500	4,300	3,800	3,400
Max. speed (balanced)***	(min^{-1})		11,200	10,200	8,700	8,300	7,400	6,600

* maximum transmittable torque depends on the bore diameter | ** at maximum bore diameter | *** higher speeds on request

SIZE	Ø18	Ø20	Ø23	Ø25	Ø30	Ø35	Ø40	Ø45	Ø50	Ø55	Ø60	Ø70	Ø80	Ø90	Ø100	Ø120	Ø140	Ø150	Ø160
300	180	200	230	250	300	350	400	450											
500			300	330	400	460	525	590	650										
700				400	480	560	640	720	800	880									
1100				590	710	830	950	1070	1190	1310	1430								
1600					970	1140	1300	1460	1630	1790	1950								
2600						1580	1810	2040	2260	2490	2700	3150							
4000							2300	2600	2900	3200	3500	4000	4600	5200					
6000							3200	3700	4100	4500	4900	5700	6500	7400					
8000									5000	5600	6100	7100	8100	9100	10000				
15000												9000	10000	11500	13000	15500	18000	19500	
25000															19000	23000	26500	28500	30500

LPH

WITH FULLY SPLIT CLAMPING HUB 4,000 – 50,000 Nm



NEW

PROPERTIES

FEATURES

- ▶ lateral mounting between shafts
- ▶ easy installation and removal
- ▶ dual flex design

MATERIAL

- ▶ **disc packs:** highly elastic spring steel
- ▶ **hubs and spacer:** high strength steel

DESIGN

Two precision machined fully split clamping hubs and spacer plate mounted to the disc pack by means of high strength screws and bushings for alignment and frictional clamping of the assembly. From series 25,000 assembly screws/superbolts must be used.

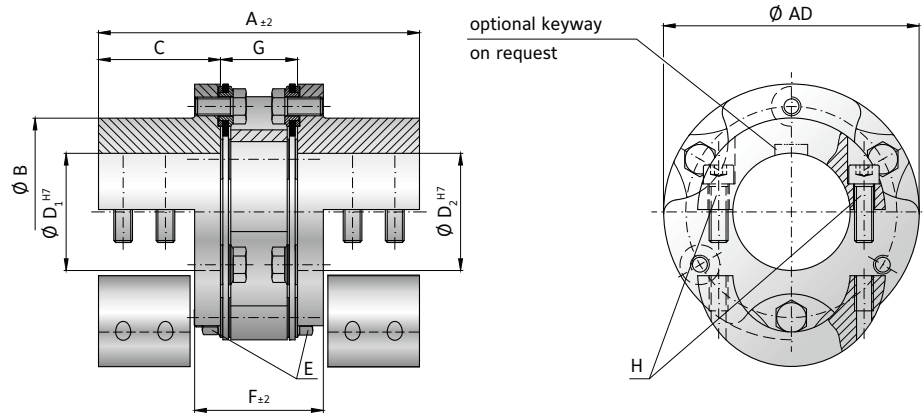

MODEL LPH D | SIZE 4000 - 25000

SIZE			4000	6000	8000	15000	25000
Rated torque*	(Nm)	T _{KN}	4,000	6,000	8,000	15,000	25,000
Maximum torque*	(Nm)	T _{KNmax}	8,000	12,000	16,000	30,000	50,000
Overall length	(mm)	A	274	302	349	420	on request
Outside diameter	(mm)	∅ AD	198	212	238	299	372
Hub diameter	(mm)	∅ B	137	149	168	220	on request
Hub fit length	(mm)	C	102	112	126	155	183
Bore diameter available from ∅ to ∅ H7	(mm)	D _{1/2}	38 - 90	39 - 95	50 - 102	70 - 150	on request
Assembly screw (ISO 4017) Tensioning nut (DIN 4032)		E	M16	M16	M20	M24	M36
Tightening torque	(Nm)		360	400	755	1,000	72
Length of center section	(mm)	F	124	132	163	190	on request
Distance between hubs	(mm)	G	70	78	97	110	on request
Clamping screw (ISO 4762)		H	8 x M14	8 x M16	8 x M20	8 x M20	8 x 24
Tightening torque	(Nm)		215	342	530	680	1,200
Moment of inertia**	(10 ⁻³ kgm ²)	J _{ges.}	104	146	280	913	on request
Weight**	(kg)		22.7	28.5	43.4	80.9	on request
Torsional stiffness	(10 ³ Nm/rad)	C _T	on request				
Axial ±	(mm)	max. values	2.5	2.5	2.5	3.0	4.0
Lateral ±	(mm)		0.5	0.5	0.6	0.7	0.8
Angular ±	(degree)		1.4	1.4	1.4	1.4	1.4
Max, speed	(min ⁻¹)		2,900	2,700	2,400	1,900	1,500
Max, speed (balanced)***	(min ⁻¹)		5,600	5,200	4,700	3,700	3,000

* maximum transmittable torque depends on the bore diameter | ** at maximum bore diameter | *** higher speeds on request

ORDERING EXAMPLE	LPH	700	D	172	25.4	40	XX
Model	●						Special designation only (e.g. special bore diameter tolerances, balancing, etc.). Contact R+W for more information.
Size		●					
Type (D)			●				
Overall length (mm)				●			
Bore diameter ∅ D1 H7					●		
Bore diameter ∅ D2 H7						●	
For custom features place an XX at the end of the part number and describe the special requirements (e.g. LPH / 700 / D / 172 / 25.4 / 40 / XX - balanced to 8,000 rpm)							

DISC PACK COUPLINGS
LP

LPZ

SPACER PLATE

350 - 5,200 Nm



NEW

PROPERTIES

FEATURES

- ▶ high torsional stiffness
- ▶ dual flex design
- ▶ for combination of hub types

MATERIAL

- ▶ **spacer plate:** high strength steel

DESIGN

For use when combining various hub designs with two disc packs and spacer plate.

From series 25,000 assembly screws/superbolts must be used.

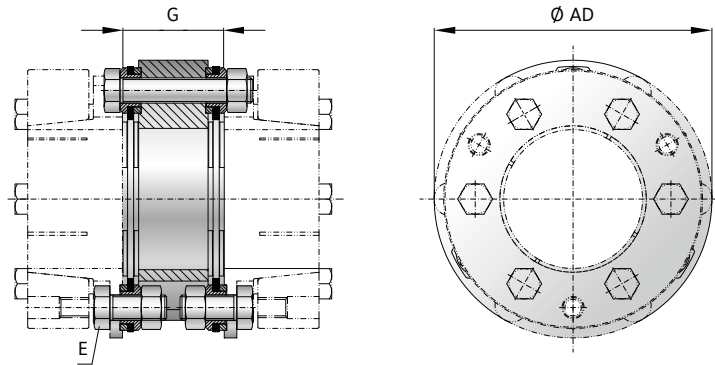

MODEL LPZ | SIZE 300 - 2600

SIZE			300	500	700	1100	1600	2600
Rated torque (Nm)	T_{KN}		350	500	700	1,100	1,600	2,600
Maximum torque (Nm)	T_{Kmax}		700	1,000	1,400	2,200	3,200	5,200
Distance between hubs (mm)	G		33	33	44	48	54	56
Outside diameter (mm)	$\varnothing AD$		99	109	128	133	150	168
Assembly screw (ISO 4017) Tensioning nut (DIN 4032)	E		M8	M8	M10	M10	M12	M12
Tightening torque (Nm)			35	40	65	95	150	165
Moment of inertia ($10^{-3}kgm^2$)	$J_{ges.}$		0.7	1	2.6	3.2	5	9
Weight (kg)			0.55	0.66	1.25	1.4	1.8	2.3
Torsional stiffness ($10^3Nm/rad$)	C_T		on request	410	on request	1,010	on request	1,520
Axial \pm (mm)	max. values		1	1	1.5	1.5	2	2
Lateral \pm (mm)			0.2	0.2	0.3	0.3	0.4	0.4
Angular \pm (degree)			1.4	1.4	1.4	1.4	1.4	1.4
Max. speed (min. ⁻¹)			5,800	5,300	4,500	4,300	3,800	3,400
Max. speed (balanced)*** (min. ⁻¹)			11,200	10,200	8,700	8,300	7,400	6,600

*** higher speeds on request

ORDERING EXAMPLE	LPZ	500	XX
Model	●		Special designation only (e.g. balancing, materials, etc.). Contact R+W for more information.
Size		●	
For custom features place an XX at the end of the part number and describe the special requirements (e.g. LPZ / 500 / XX - balanced to 10,000 rpm)			



SPACER PLATE

4,000 - 50,000 Nm



NEW

PROPERTIES

FEATURES

- ▶ high torsional stiffness
- ▶ dual flex design
- ▶ for combination of hub types

MATERIAL

- ▶ **spacer plate:** high strength steel

DESIGN

For use when combining various hub designs with two disc packs and spacer plate.

From series 25,000 assembly screws/superbolts must be used.

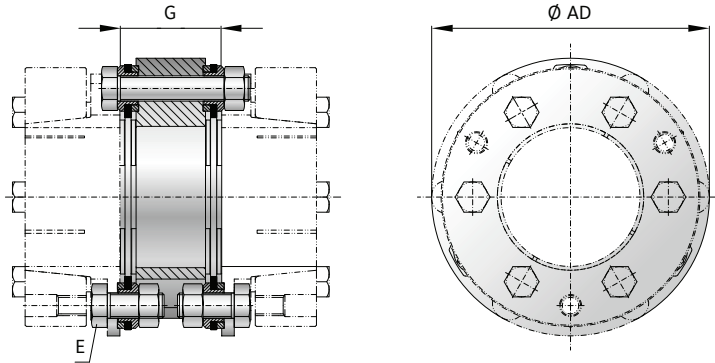

DISC PACK COUPLINGS
LP

MODEL LPZ | SIZE 4000 - 25000

SIZE			4000	6000	8000	15000	25000
Rated torque (Nm)	T_{KN}		4,000	6,000	8,000	15,000	25,000
Maximum torque (Nm)	T_{Kmax}		8,000	12,000	16,000	30,000	50,000
Distance between hubs (mm)	G		70	78	97	110	on request
Outside diameter (mm)	ϕAD		198	212	238	299	372
Assembly screw (ISO 4017) Tensioning nut (DIN 4032)	E		M16	M16	M20	M24	M36
Tightening torque (Nm)			360	400	755	1,200	72
Moment of inertia ($10^{-3}kgm^2$)	$J_{ges.}$		18	27	54	164	on request
Weight (kg)			3.7	4.8	7.5	14	on request
Torsional stiffness ($10^3Nm/rad$)	C_T		on request	3,200	on request	12,900	on request
Axial \pm (mm)	max. values		2.5	2.5	2.5	3	4
Lateral \pm (mm)			0.5	0.5	0.6	0.7	0.8
Angular \pm (degree)			1.4	1.4	1.4	1.4	1.4
Max. speed (min. ⁻¹)			2,900	2,700	2,400	1,900	1,500
Max. speed (balanced)*** (min. ⁻¹)			5,600	5,200	4,700	3,700	3,000

*** higher speeds on request

ORDERING EXAMPLE	LPZ	6000	XX
Model	●		Special designation only (e.g. balancing, materials, etc.). Contact R+W for more information.
Size		●	
For custom features place an XX at the end of the part number and describe the special requirements (e.g. LPZ / 6000 / XX - balanced to 5,000 rpm)			



WITH KEYWAY MOUNTING

500 - 24,000 Nm

API 610 - METRIC
(API 671 OPTIONAL)

PROPERTIES



FEATURES

- ▶ lateral installation and removal without disturbing shaft hubs
- ▶ fail safe in case of disc pack rupture
- ▶ standard balance quality of AGMA Class 9

MATERIAL

- ▶ **disc packs:** highly elastic spring steel
- ▶ **hubs and spacer:** high strength steel

DESIGN

Two precision machined coupling hubs mounted to the disc pack spacer with connection of the disc packs by means of high strength screws and bushings for alignment and frictional clamping of the assembly. Axial retention of the hubs on the shaft with DIN 916 set screws.

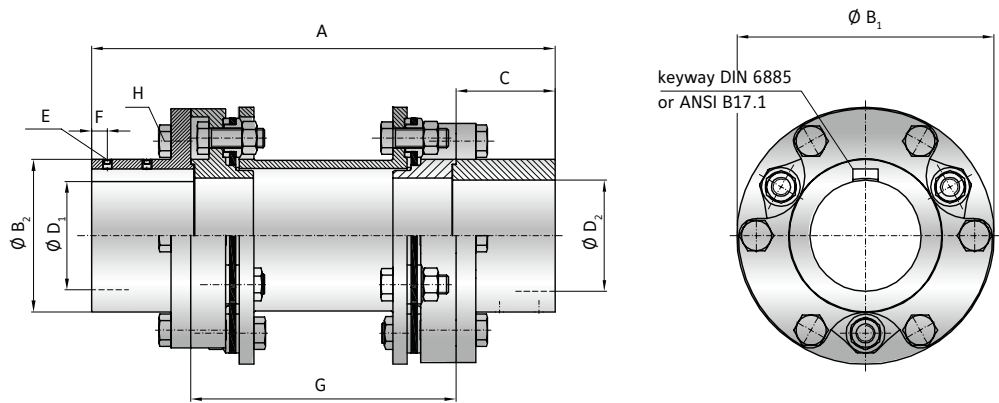

MODEL LPA | SIZE 500 - 12000

SIZE	500		800		2500		5000		8000		12000			
Power rating (kW/100 rpm)	P _{KN}		5		8		26.2		52		84		126	
Rated torque (Nm)	T _{KN}		500		800		2,500		5,000		8,000		12,000	
Maximum torque (Nm)	T _{Kmax}		1,000		1,600		5,000		10,000		16,000		24,000	
Overall length (mm)	A		190 230		250 290		332 402		360 430		450		500	
Outside diameter (mm)	B ₁		116		142		190		231		298		324	
Hub diameter (mm)	B ₂		71		84		102		130		160		192	
Hub fit length (mm)	C		45		55		75		90		100		125	
Bore diameter available from Ø to Ø H7 (mm)	D _{1/2}		23 - 50		25 - 60		31 - 75		39 - 95		50 - 115		70 - 140	
Set screw (DIN 916)	E		2 × M6		2 × M6		2 × M8		2 × M10		2 × M10		2 × M12	
Screw location (mm)	F		7		10		14		15		15		20	
Spacer length (mm)	G		100 140		140 180		180 250		180 250		250		250	
Assembly screw (ISO 4017) Tensioning nut (DIN 4032)	H		M8		M10		M16		M20		M24		M24	
Tightening torque (Nm)			41		83		355		690		1,200		1,200	
Moment of inertia** (10 ⁻³ kgm ²)			8 8.4		21.8 22.3		85.8 88.4		248 256		901		1,350	
Material			steel		steel		steel		steel		steel		steel	
Weight** (kg)			5 5.4		9.2 9.6		20.8 22		39 41		83		105	
Axial ± (mm)			0.75		1		1.3		1.5		1.7		2	
Lateral ± (mm)			0.7 1.1		1 1.5		1.3 2		1.1 1.9		1.5		1.5	
Angular ± (degree)			1°		1°		1°		1°		1°		1°	
Max. speed (1/min.)			7,600		6,400		5,300		3,900		3,100		2,500	
Max. speed (balanced) (1/min.)			18,800		15,100		12,800		9,800		8,100		6,200	

** at maximum bore diameter

ORDERING EXAMPLE	LPA	800	250	41.28	38	XX
Model	●					
Size		●				
Overall length (mm)			●			
Bore diameter Ø D1 H7				●		
Bore diameter Ø D2 H7					●	

Special designation only (e.g. special bore diameter tolerances, balancing, etc.). Contact R+W for more information.

For custom features place an XX at the end of the part number and describe the special requirements (e.g. LPA / 800 / 250 / 41.28 / 38 / XX - balanced to 15,000 rpm)

PROPERTIES

FEATURES

- ▶ lateral installation and removal without disturbing shaft hubs
- ▶ flail safe in case of disc pack rupture
- ▶ standard balance quality of AGMA Class 9

MATERIAL

- ▶ **disc packs:** highly elastic spring steel
- ▶ **hubs and spacer:** high strength steel

DESIGN

Two precision machined coupling hubs mounted to the disc pack spacer with connection of the disc packs by means of high strength screws and bushings for alignment and frictional clamping of the assembly. Axial retention of the hubs on the shaft with DIN 916 set screws.

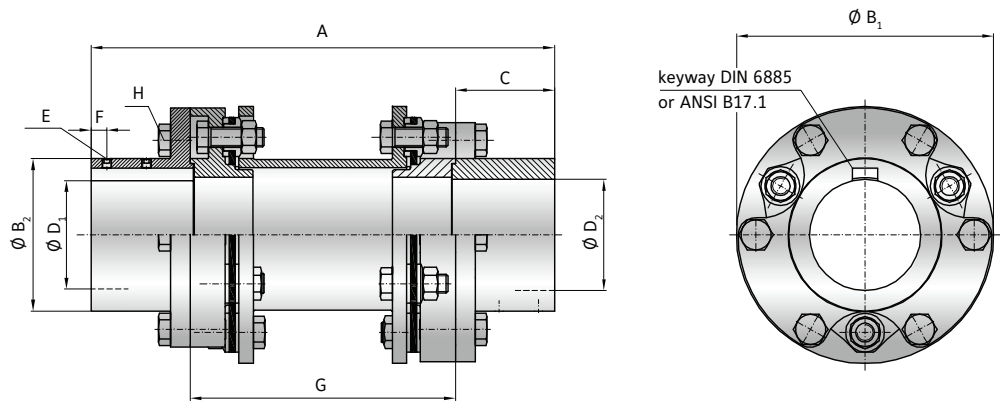

MODEL LPAI | SIZE 500 - 12000

SIZE		500	800	2500	5000	8000	12000
Power rating (kW/100 rpm)	P_{KN}	5	8	26.2	52	84	126
Rated torque (Nm)	T_{KN}	500	800	2,500	5,000	8,000	12,000
Maximum torque (Nm)	T_{Kmax}	1,000	1,600	5,000	10,000	16,000	24,000
Overall length (mm)	A	217 268	237 288	330 381	358 409	429	479
Outside diameter (mm)	B_1	116	142	190	231	298	324
Hub diameter (mm)	B_2	71	84	102	130	160	192
Hub fit length (mm)	C	45	55	75	90	100	125
Bore diameter available from \varnothing to \varnothing H7 (mm)	$D_{1/2}$	23 - 50	25 - 60	31 - 75	39 - 95	50 - 115	70 - 140
Set screw (DIN 916)	E	2 x 1/4"-20	2 x 1/4"-20	2 x 5/16"-18	2 x 3/8"-16	2 x 1/2"-13	2 x 1/2"-13
Screw location (mm)	F	7	10	14	15	15	20
Spacer length (mm)	G	127/5" 178/7"	127/5" 178/7"	178/7" 229/9"	178/7" 229/9"	229/9"	229/9"
Assembly screw (ISO 4017) Tensioning nut (DIN 4032)	H	5/16"-18	3/8"-16	5/8"-11	3/4"-10	1"-8	1"-8
Tightening torque (Nm)		38	68	320	595	1,100	1,100
Moment of inertia** (10 ⁻³ kgm ²)		8.3 8.8	21 22.3	85 87	248 254	890	1,344
Material		steel	steel	steel	steel	steel	steel
Weight** (kg)		5.3 5.7	9.1 9.6	20.8 21.6	38.9 40	82.3	104
Axial ± (mm)		0.75	1	1.3	1.5	1.7	2
Lateral ± (mm)		1 1.5	0.9 1.4	1.3 1.8	1.1 1.6	1.3	1.3
Angular ± (degree)		1°	1°	1°	1°	1°	1°
Max. speed (1/min.)		7,600	6,400	5,300	3,900	3,100	2,500
Max. speed (balanced)*** (1/min.)		18,800	15,100	12,800	9,800	8,100	6,200

** at maximum bore diameter | *** higher speeds on request

ORDERING EXAMPLE	LPAI	800	237	25.4	50.8	XX
Model	●					
Size		●				
Overall length (mm)			●			
Bore diameter \varnothing D1 H7				●		
Bore diameter \varnothing D2 H7					●	
Special designation only (e.g. special bore diameter tolerances, balancing, etc.). Contact R+W for more information.						
For custom features place an XX at the end of the part number and describe the special requirements (e.g. LPA / 800 / 237 / 25.4 / 50.8 / XX - balanced to 15,000 rpm)						

LPA

LPAI

API 610 / API 671 MORE INFORMATION



DEFINITION OF TERMS / GENERAL INFORMATION

- ▶ API is the American Petroleum Institute
- ▶ API 610 and 671 seek to harmonize the technical requirements of pump and compressor systems in the American oil and gas industry, and are used worldwide
- ▶ Couplings built in accordance with API 671 must meet stricter requirements than API 610

REQUIREMENTS FOR COUPLINGS

API 610

- ▶ Design according to service factor of at least 1.0 (unless otherwise specified)
- ▶ Anti-flail safety required to prevent the spacer from being thrown in the event of disc pack rupture
- ▶ Spacer length of at least 5"
- ▶ Balance requirements vary by speed (contact R+W)

API 671

- ▶ Design according to service factor of at least 1.5 (unless otherwise specified)
- ▶ Anti-flail safety required to prevent the spacer from being thrown in the event of disc pack rupture
- ▶ Match-weighted screws with documentation for future replacement
- ▶ Balance requirements vary by speed (contact R+W)

INFORMATION REQUIRED FOR DESIGN

- ▶ Drive power or nominal / peak application torque
- ▶ Rotational speed
- ▶ Bore diameters
- ▶ Keyway standards or sizes
- ▶ Distance between shaft ends (DBSE)
- ▶ Ambient temperature
- ▶ Balance grade (if different from AGMA Class 9)

Special designs are available on request!

SAMPLE DESIGN LPA 2500 API 610

Customer	Order number	Quote number	Drawing number

Characteristic	Unit	Value
Drive power	KW	300
Speed	1/min	1900
Torque	Nm	1508
Service factor		1.66
Rated torque	Nm	2500
Distance between shaft ends	mm	260
Ambient temperature	°C	40

Dynamic balancing	
Balance quality	G 6.3
Procedure	
Component balance	

Balance grade AGMA Class 9

Coupling qualifies for operating conditions

Coupling Type / Size / Overall length (mm)

LPA / 2500 / 402

Characteristic	Unit	Value
Rated torque	Nm	2500
Maximum torque	Nm	5000
Moment of inertia	10 ⁻³ kgm ²	88.4
Approximate weight	kg	22
Max. axial misalignment	mm	1.3
Max. angular misalignment	degree	1
Max. lateral misalignment	mm	2
Max. allowable speed	1/min.	12800
Overall length A	mm	402
Outside diameter AD	mm	190
Hub diameter B	mm	102
Hub fit length C	mm	75
Spacer length G	mm	250

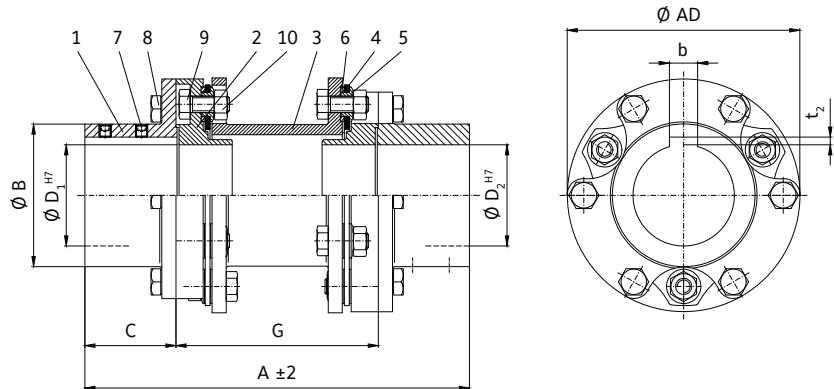

Driving side					
Hub	mm	Tol.	keyw.	mm	Tol.
D ₁	65	H7	b	18	JS9
Style	Cylindrical		t ₂	4.4	

Driven side					
Hub	mm	Tol.	keyw.	mm	Tol.
D ₂	65	H7	b	18	JS9
Style	Cylindrical		t ₂	4.4	

Keyway
DIN 6885-1

Item	Quantity	Description	Standard	Part designation	Material
1	2	Keyway hub	-	820124	16MnCr5 (1.7131)
2	2	Guard ring	-	820254	16MnCr5 (1.7131)
3	1	Spacer	-	820321	16MnCr5 (1.7131)
4	12	Flexible disc	-	820008	X12CrNi17 7 (1.4310)
5	12	Sleeve	-	820508	42CrMo4+QT
6	12	Bushing	-	820408	42CrMo4+QT
7	4	Set screw	ISO 4029	M8	-
8	12	Assembly screw	ISO 4017	M16x35 - 12.9	-
9	12	Assembly screw	ISO 4017	M16x40 - 12.9	-
10	12	Tensioning nut	ISO 4032	M16 -12	-

Surface protection: oiled



INTELLIGENT COUPLING WITH INTEGRAL SENSOR TECHNOLOGY 350 – 50,000 Nm



NEW

PROPERTIES

FEATURES

- ▶ recording of various performance characteristics
- ▶ measurement accuracy within <1% (torque)
- ▶ amplifier on board
- ▶ evaluation directly on integral chip
- ▶ wireless transmission directly to mobile device or PC (with gateway)
- ▶ data export in CSV

MEASUREMENTS TAKEN

- ▶ speed
- ▶ vibration
- ▶ torque
- ▶ optional axial force

DESIGN

- ▶ spacer with integral sensor technology
- ▶ coupling properties remain unchanged (see previous pages)
- ▶ custom configurations on request

SPECIFICATIONS

- ▶ Bluetooth Low Energy
- ▶ magnetic charging port
- ▶ sampling rate of 500 Hz
- ▶ transmission rate of up to 500 Hz
- ▶ speed up to 3000 rpm

POWER SUPPLY

Battery power

- ▶ no wiring necessary
- ▶ easy installation
- ▶ for use with mobile app

Inductive power

- ▶ for fixed installations
- ▶ continuous and uninterrupted measurement (24/7 operation)

COUPLING MODELS AVAILABLE WITH SENSOR UNIT

LP2



- ▶ with keyway mounting
- ▶ positive drive connection
- ▶ easy installation

LP3



- ▶ with conical clamping ring hubs
- ▶ frictional shaft connection
- ▶ zero backlash torque transmission in reversing applications

LP5



- ▶ with clamping hubs
- ▶ frictional shaft connection
- ▶ zero backlash torque transmission in reversing applications
- ▶ easy installation

LPH



- ▶ with fully split clamping hubs
- ▶ frictional shaft connection
- ▶ zero backlash torque transmission in reversing applications
- ▶ lateral mounting

SPECIAL OPTIONS

- ▶ e.g. with flange connections
- ▶ or fully customized



INTELLIGENT COUPLING WITH INTEGRAL SENSOR TECHNOLOGY 350 – 50,000 Nm

DATA COLLECTION



GATEWAY

- ▶ connection to PC via USB port
- ▶ PLC or cloud solutions via 8 analog outputs (-10 to 10 V)
- ▶ 4 digital outputs for programmable status updates
- ▶ SMA connector for external antennas

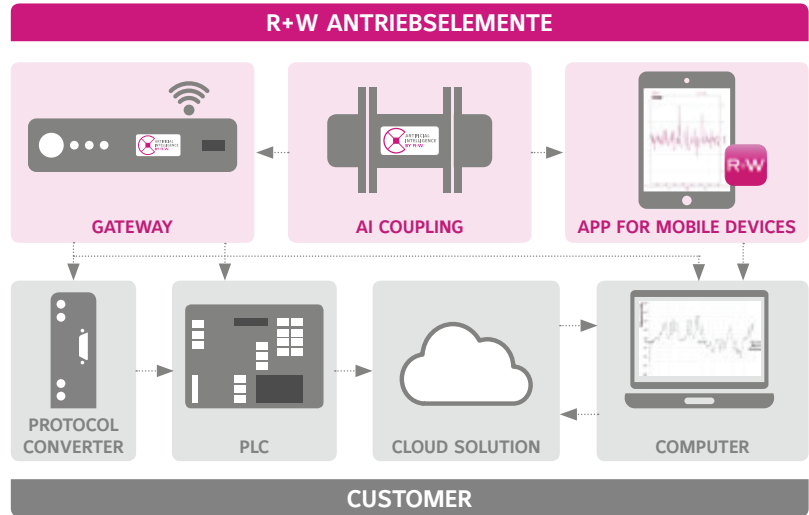

DISC PACK COUPLINGS
LP

R+W APP

- ▶ display of all measurement variables
- ▶ min / max and average values
- ▶ tare function
- ▶ various chart types
- ▶ detailed measurement curves
- ▶ intuitive gesture control
- ▶ retains data for further analysis
- ▶ export in CSV format

Requirements:

- ▶ Android tablet or smartphone
- ▶ version 6.0 or higher
- ▶ minimum 30 MB free space
- ▶ Bluetooth 4.0 or higher





OPTIONS / SPECIAL SOLUTIONS / HIGHER TORQUES

TORSIONALLY STIFF DISC PACK COUPLINGS - FURTHER INFORMATION



WITH CLAMPING HUB

- ▶ easy installation
- ▶ zero backlash torque transmission
- ▶ customer specified length available
- ▶ dual flex design
- ▶ keyway optional on request



WITH FULLY SPLIT CLAMPING HUB

- ▶ easy installation and removal
- ▶ zero backlash torque transmission
- ▶ customer specified length available
- ▶ dual flex design
- ▶ keyway optional on request



WITH CONICAL CLAMPING RING HUB AND FLANGE MOUNTING FOR CONNECTION TO TORQUE TRANSDUCERS

- ▶ high torsional stiffness
- ▶ high clamping pressure
- ▶ zero backlash torque transmission



WITH INTEGRAL COOLANT DELIVERY PIPE

- ▶ spacer: carbon fiber, aluminum or steel
- ▶ for high speeds
- ▶ customer specified length available
- ▶ dual flex design

TORSIONALLY STIFF DISC PACK COUPLINGS - FURTHER INFORMATION

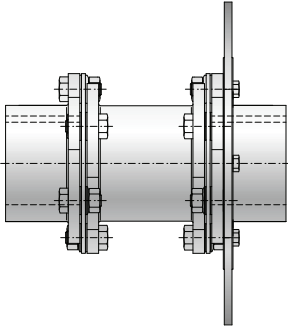

WITH BRAKE DISC

- ▶ brake disc according to customer requirements
- ▶ single or dual flex
- ▶ with keyway mounting, conical clamping rings, clamping hubs, fully split clamping hubs or flange mounting

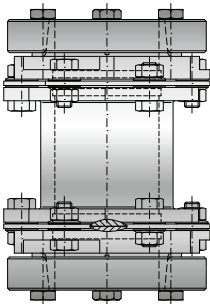

WITH VERTICAL SUPPORT

- ▶ for vertical installations
- ▶ with keyway mounting, conical clamping rings, clamping hubs, fully split clamping hubs or flange mounting

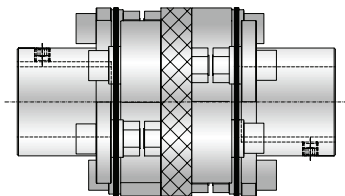

WITH ELECTRICAL ISOLATING

- ▶ single or dual flex
- ▶ with keyway mounting, conical clamping rings, clamping hubs, fully split clamping hubs or flange mounting

HIGHER TORQUES ON REQUEST